

## Specification of: DDMP 12/12 M6A4 DA8 230V-1F

### High performance centrifugal fan DDMP

Double width, double inlet (DWDI), direct drive, forward curved blades fan. Lap-jointed scroll made of galvanized steel (EN 10142), assembled through a high-technology roller-locked seaming. Straight cut off plate at fan discharge. Impeller with forward curved blades of galvanized steel plate, directly mounted on a brushless, permanent magnets, external rotor motor, without transmission losses, dynamically balanced according to DIN ISO 21940-11. High efficient 2 kW single-phase driver sensor-less algorithm with integrated active PFC and thermal derating protection. Driver directly installed on the scroll, and factory-configured, for a plug and play solution: no further configuration is needed. Continuous speed control of the Drive System by 0 ... 10 V analogue signal, or with Modbus RS485-compliant interface. The complete drive system is in protection class IP 54. Power supply 230V – 50/60 Hz. Air performance ratings according to AMCA 210-07 (Fig. 12) and ISO 5801 (Fig. 69 c and par. 30.2 f).

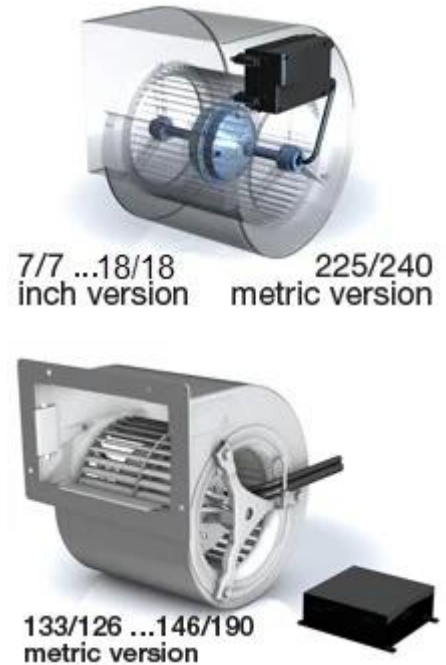

## Technical data of the fan: DDMP 12/12 M6A4 DA8 230V-1F

[fulfills the ErP requirements 2015](#)

Description	Value Dimension
<b>Specified duty point</b>	
<b>Actual duty point</b>	
Installation acc. DIN 24163 Part 1	B
Reference density (Rho1)	1.20 kg/m <sup>3</sup>
Medium temperature (t)	20 C
Fan weight	25 kg
<small>This duty point can only be reached by using an inverter/controller for motor speed control!</small>	
<b>Rated data</b>	
Phases-Voltage-Frequency	1~230-50/60 V-Hz
Rated motor current (I <sub>N</sub> )	N/A A
<b>operational limits</b>	
Max. absorbed power (P <sub>1max</sub> )	1.789 kW
Temperature range of conveying medium (t <sub>min</sub> ...t <sub>max</sub> )	-20...40 C
<b>ErP-Data at best efficiency and density - kg/m<sup>3</sup></b>	
measurement- / efficiency category	B / total
design status of VSD	VSD is integrated
overall efficiency (ETA <sub>opt</sub> )	56.7 %
achieved efficiency grade (N <sub>ist</sub> )	61.7
required efficiency grade in 2013 / 2015 (N)	42 / 49
Air flow rate (V <sub>opt</sub> )	4471 m <sup>3</sup> /h
pressure rise (dp <sub>opt</sub> )	690 Pa
Fan speed (n <sub>vopt</sub> )	1296 min <sup>-1</sup>
motor power input (P <sub>1opt</sub> )	1.51 kW
specific ratio (d <sub>dpopt</sub> )	1.007

## Fan curve to DDMP 12/12 M6A4 DA8 230V-1F

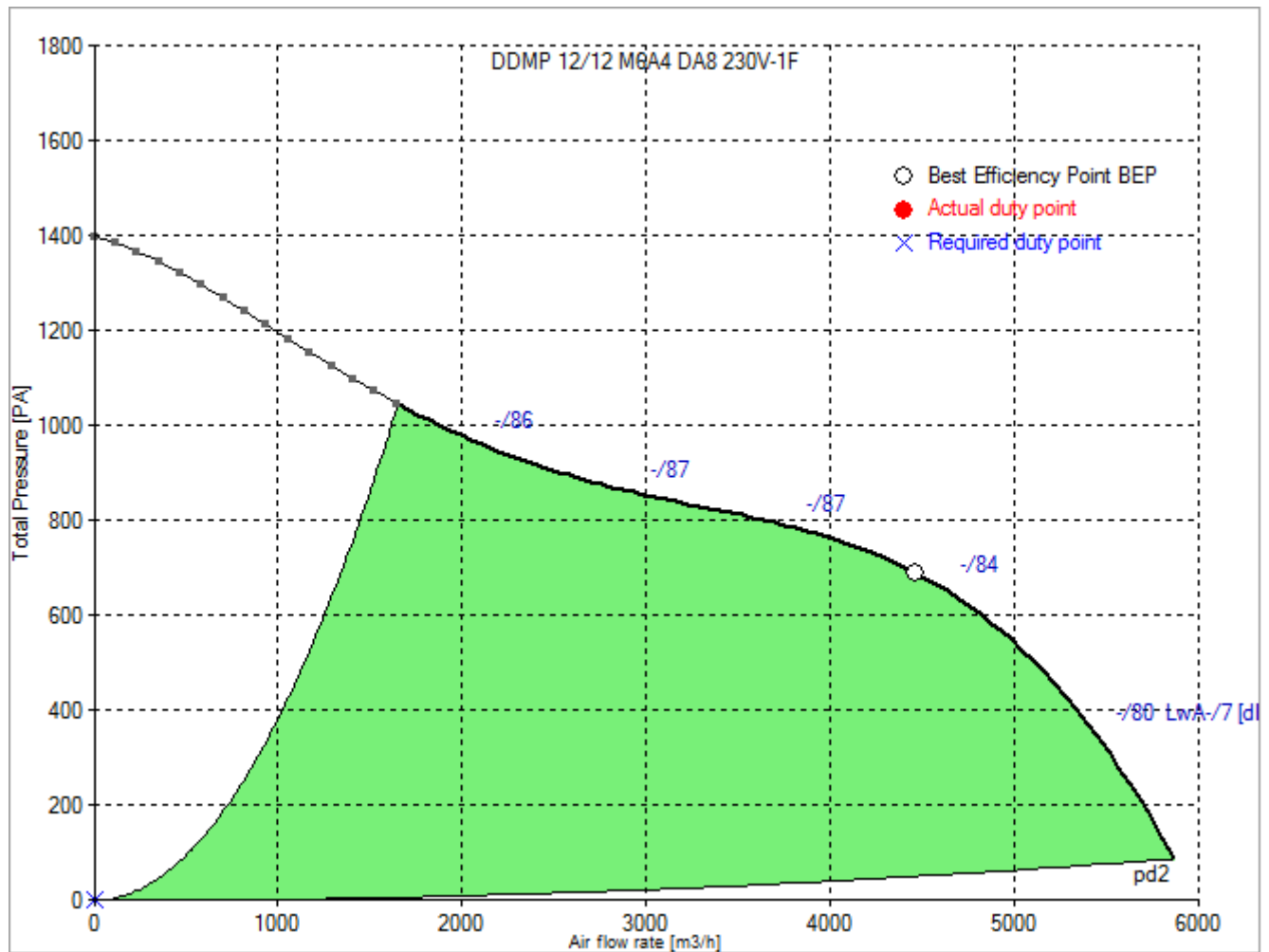

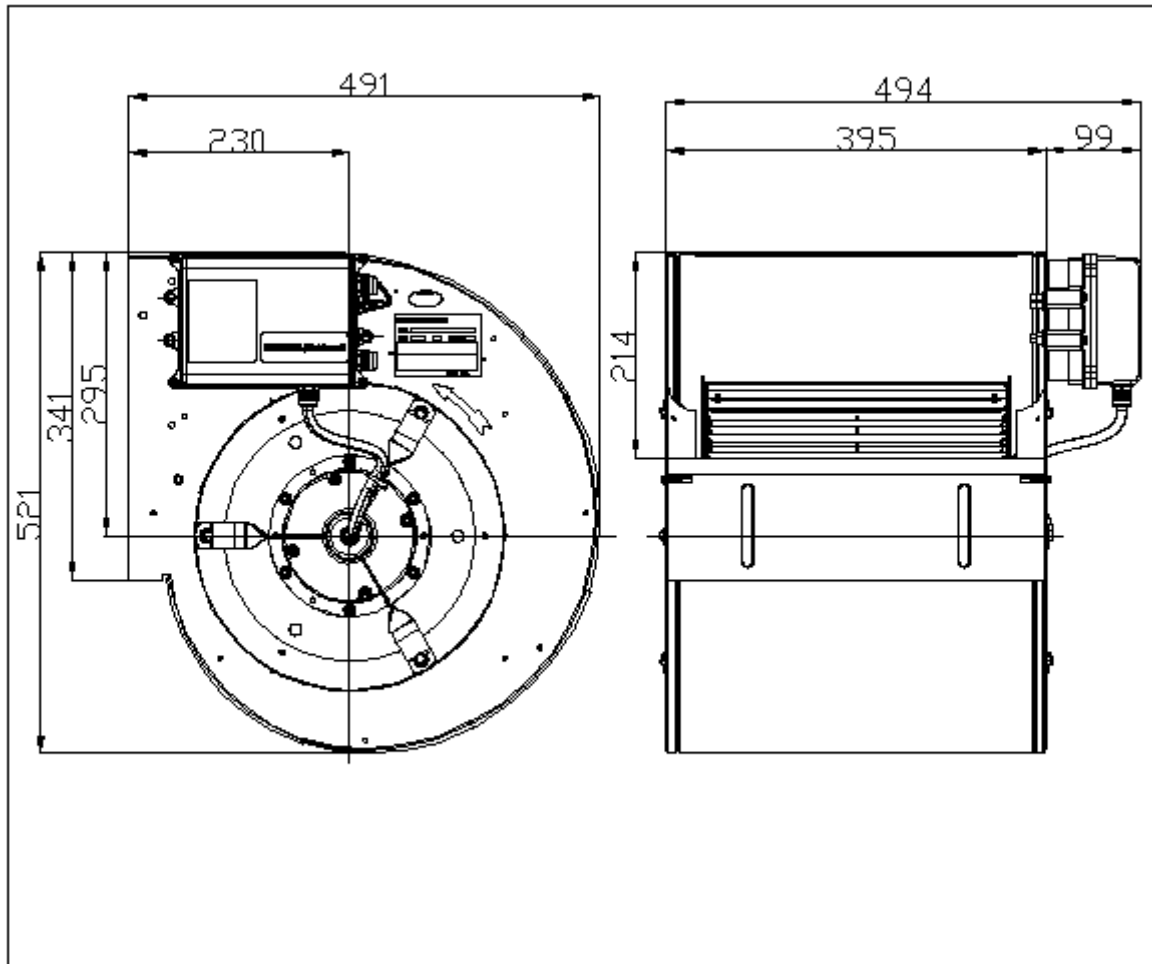

Rotation:  
Handing:

RD  
90

## Wiring diagram of the fan DDMP 12/12 M6A4 DA8 230V-1F

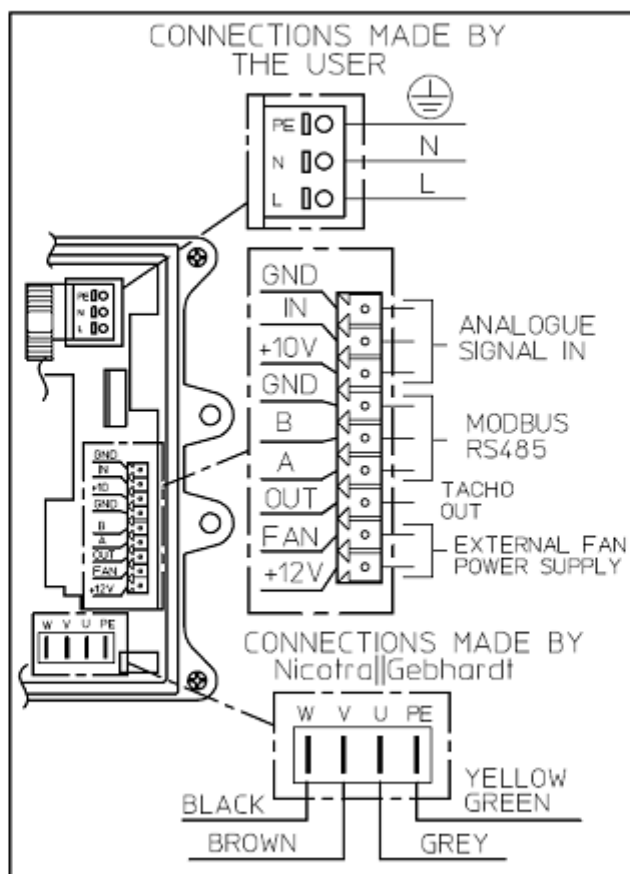

DDMP 2KW

28-11-2017 5X

Wiring diagram for connection to: [mains - VSD - motor](#)  
 Rotation: [LG](#)